

H8S/2169 Series TFP-144
User System Interface Cable
(HS2169ECN61H)
for E6000 Emulator

User's Manual



HS2169ECN61HE(B)

Cautions

1. Renesas neither warrants nor grants licenses of any rights of Renesas's or any third party's patent, copyright, trademark, or other intellectual property rights for information contained in this document. Renesas bears no responsibility for problems that may arise with third party's rights, including intellectual property rights, in connection with use of the information contained in this document.
2. Products and product specifications may be subject to change without notice. Confirm that you have received the latest product standards or specifications before final design, purchase or use.
3. Renesas makes every attempt to ensure that its products are of high quality and reliability. However, contact Renesas's sales office before using the product in an application that demands especially high quality and reliability or where its failure or malfunction may directly threaten human life or cause risk of bodily injury, such as aerospace, aeronautics, nuclear power, combustion control, transportation, traffic, safety equipment or medical equipment for life support.
4. Design your application so that the product is used within the ranges guaranteed by Renesas particularly for maximum rating, operating supply voltage range, heat radiation characteristics, installation conditions and other characteristics. Renesas bears no responsibility for failure or damage when used beyond the guaranteed ranges. Even within the guaranteed ranges, consider normally foreseeable failure rates or failure modes in semiconductor devices and employ systemic measures such as fail-safes, so that the equipment incorporating Renesas product does not cause bodily injury, fire or other consequential damage due to operation of the Renesas product.
5. This product is not designed to be radiation resistant.
6. No one is permitted to reproduce or duplicate, in any form, the whole or part of this document without written approval from Renesas.
7. Contact Renesas's sales office for any questions regarding this document or Renesas semiconductor products.

Preface

Thank you for purchasing this user system interface cable (HS2169ECN61H) for the Renesas's original microcomputer H8S/2169 series.

The HS2169ECN61H is a user system interface cable that connects an H8S/2148 series E6000 emulator (HS2148EPI61H; hereinafter referred to as the emulator) to the IC socket for a TFP-144 package and expansion I/O board (HS2169EIO61H) for the H8S/2169 series MCU on the user system.

Contents

Section 1	Configuration.....	1
Section 2	Connection Procedures.....	3
2.1	Connecting User System Interface Cable to Expansion I/O board.....	3
2.2	Connecting User System Interface Cable to User System.....	5
2.2.1	Installing IC Socket.....	5
2.2.2	Soldering IC Socket.....	6
2.2.3	Inserting Cable Head.....	7
2.2.4	Fastening Cable Head.....	7
2.2.5	Fastening Cable Body.....	9
2.3	Recommended Dimensions for User System Mount Pad.....	10
2.4	Dimensions for User System Interface Cable Head.....	11
2.5	Resulting Dimensions after Connecting User System Interface Cable.....	12
Section 3	Installing the MCU to the User System.....	13
Section 4	Verifying Operation.....	15
Section 5	Notice.....	16

Section 1 Configuration

CAUTION

Use an NQPACK144SE socket (manufactured by Tokyo Eletech Corporation) for the TFP-144 package IC socket on the user system.

Figure 1 shows the configuration of the HS2169ECN61H user system interface cable for the TFP-144 package.

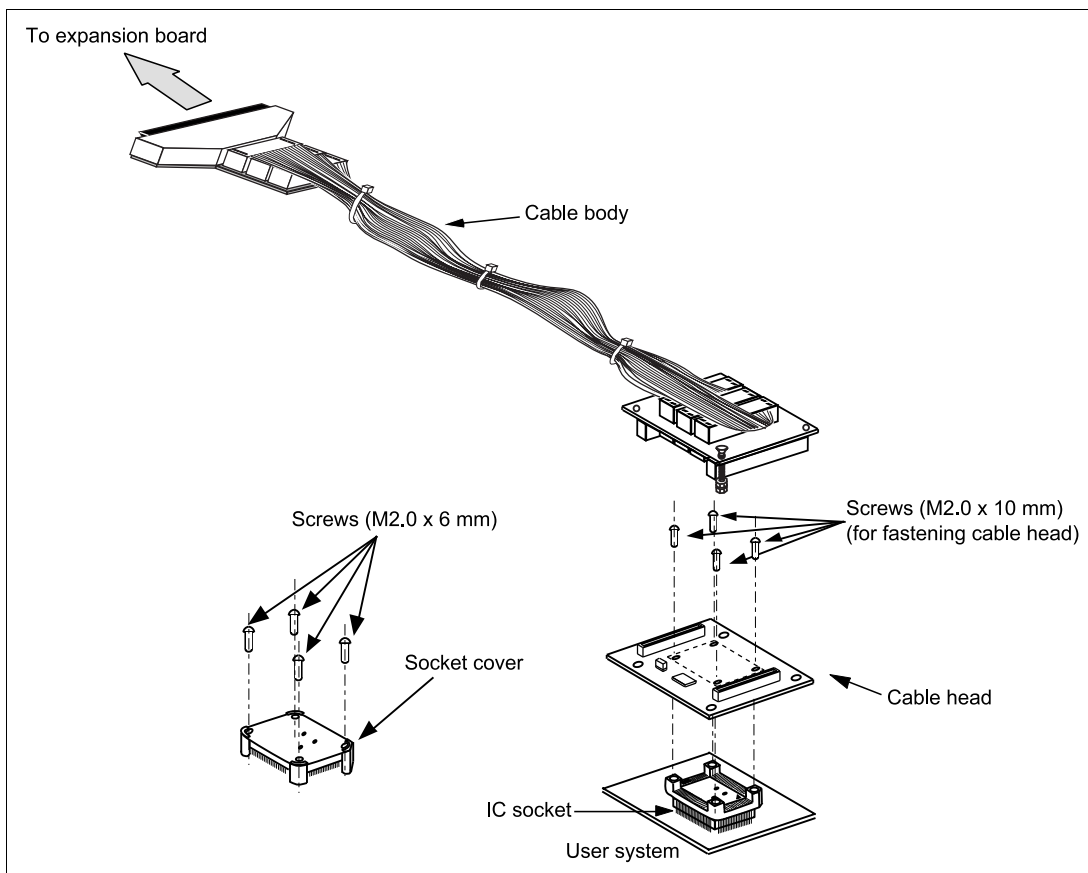

Figure 1 HS2169ECN61H User System Interface Cable

Table 1 lists the HS2169ECN61H components. Please make sure you have all of these components when unpacking.

Table 1 HS2169ECN61H Components

No.	Component	Quantity	Remarks
1	Cable body	1	Flat cable
2	Cable head	1	
3	IC socket	1	For the TFP-144 package
4	Socket cover	1	For installing an TFP-144 packaged MCU
5	Screws (M2.0 x 10 mm)	4	For fastening cable head
6	Screws (M2.0 x 6 mm)	4	For installing an TFP-144 packaged MCU
7	Guide pins (ϕ 1 mm)	3	For determining the IC socket location
8	Screwdriver	1	For tightening screws
9	Documentation	1	User's manual for HS2169ECN61H (this manual)

Section 2 Connection Procedures

2.1 Connecting User System Interface Cable to Expansion I/O board

WARNING

Observe the precautions listed below. Failure to do so will result in a FIRE HAZARD and will damage the user system and the emulator product or will result in PERSONAL INJURY. The USER PROGRAM will be LOST.

- 1. Always switch OFF the user system and the emulator product before the USER SYSTEM INTERFACE CABLE is connected to or removed from any part. Before connecting, make sure that pin 1 on both sides are correctly aligned.**
- 2. The user system interface cable dedicated to the emulator must be used.**

To connect the cable body to the emulator station, follow the instructions below.

1. Make sure the user system and emulator station are turned off.

CAUTION

When connecting or removing the user system interface cable, apply force only in the direction suitable for connection or removal, while making sure not to bend or twist the cable or connectors. Otherwise, the connectors will be damaged.

2. Connect the expansion I/O board labeled USER INTERFACE CABLE and the user system interface cable.

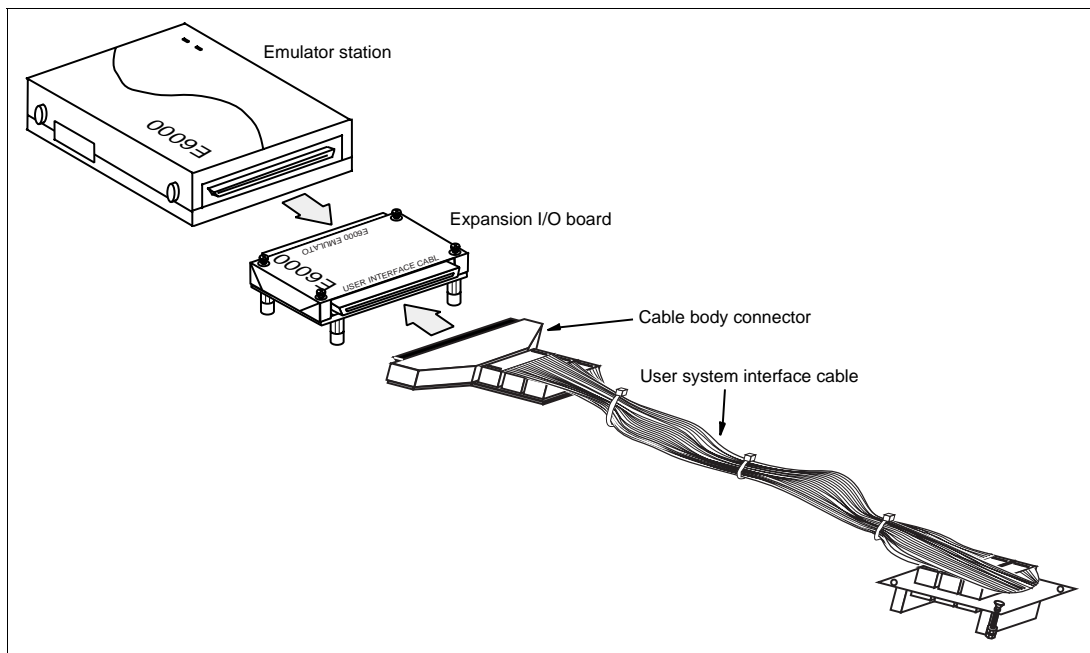

Figure 2 Connecting User System Interface Cable to Expansion I/O Board

2.2 Connecting User System Interface Cable to User System

WARNING

Always switch OFF the user system and the emulator product before the USER SYSTEM INTERFACE CABLE is connected to or removed from any part. Before connecting, make sure that pin 1 on both sides are correctly aligned. Failure to do so will result in a FIRE HAZARD and will damage the user system, the emulator product, and the expansion I/O board or will result in PERSONAL INJURY. The USER PROGRAM will be LOST.

To connect the cable head to the user system, follow the instructions below.

2.2.1 Installing IC Socket

After checking the location of pin 1 on the IC socket fasten it to the user system before soldering.

CAUTION

After confirming the location of pin 1 on the IC socket, apply epoxy resin adhesive to the end of the four projections at the bottom of the IC socket, and fasten it to the user system.

Use the guide pins provided to determine where to install the IC socket, as shown in figure 3.

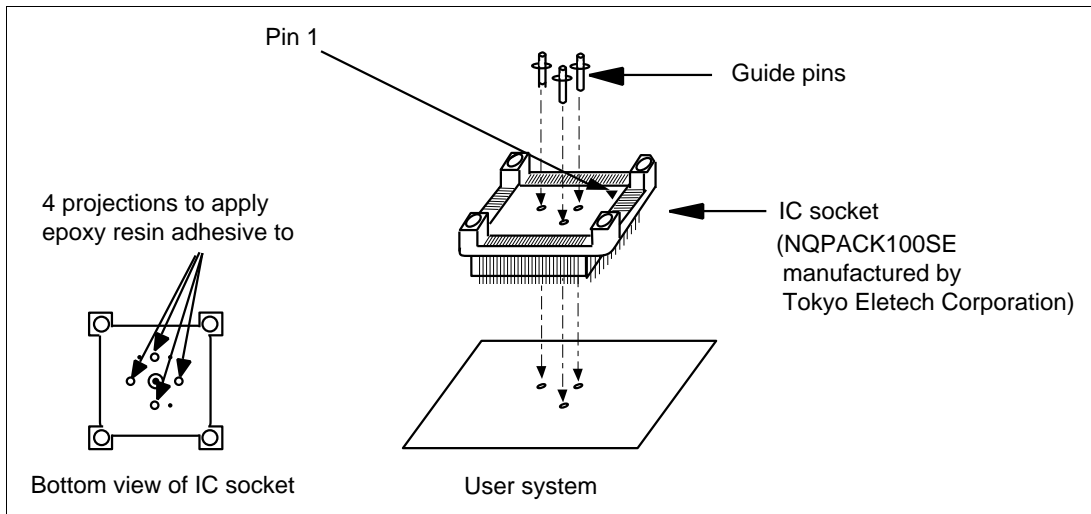

Figure 3 Location Setting of IC Socket

2.2.2 Soldering IC Socket

After fastening, solder the IC socket for a TFP-144 package to the user system.

CAUTION

Be sure to completely solder the leads so that the solder slopes gently over the leads and forms solder fillets. (Use slightly more solder than the MCU.)

2.2.3 Inserting Cable Head

CAUTION

Check the location of pin 1 before inserting.

Align pin 1 on the IC socket for an TFP-144 package on the user system with pin 1 on the user system interface cable head, and insert the user system interface cable head into the IC socket on the user system, as shown in figure 4.

2.2.4 Fastening Cable Head

CAUTION

1. Use a screwdriver whose head matches the screw head.
2. The tightening torque must be 0.054 N•m or less.
If the applied torque cannot be accurately measured, stop tightening when the force required to turn the screw becomes significantly greater than that needed when first tightening. If a screw is tightened too much, the screw head may break or an IC socket contact error may be caused by a crack in the IC socket solder.
3. If the emulator does not operate correctly, cracks might have occurred in the solder. Check conduction with a tester and re-solder the IC socket if necessary.

Fasten the user system interface cable head to the IC socket for an TFP-144 package on the user system with the four screws (M2.0 x 10 mm) provided. Each screw should be tightened a little at a time, alternating between screws on opposing corners. Take special care, such as manually securing the IC socket soldered area, to prevent the soldered IC socket from being damaged by overtightening the screws or twisting the components.

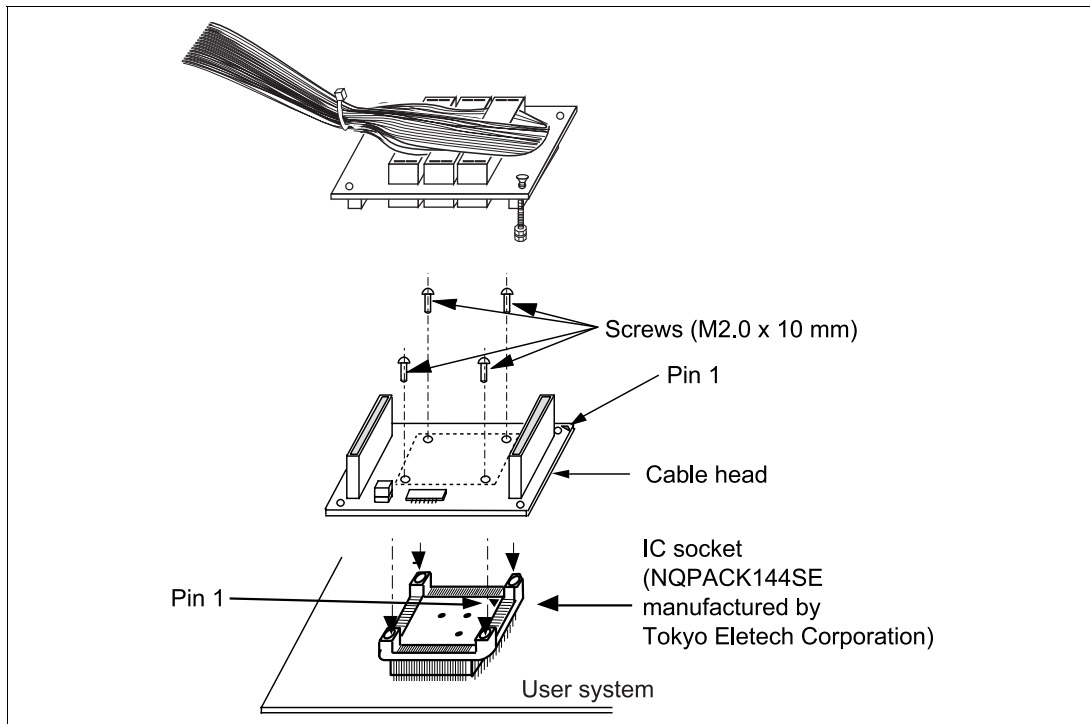

Figure 4 Connecting User System Interface Cable to User System

2.2.5 Fastening Cable Body

Connect the cable body to the cable head.

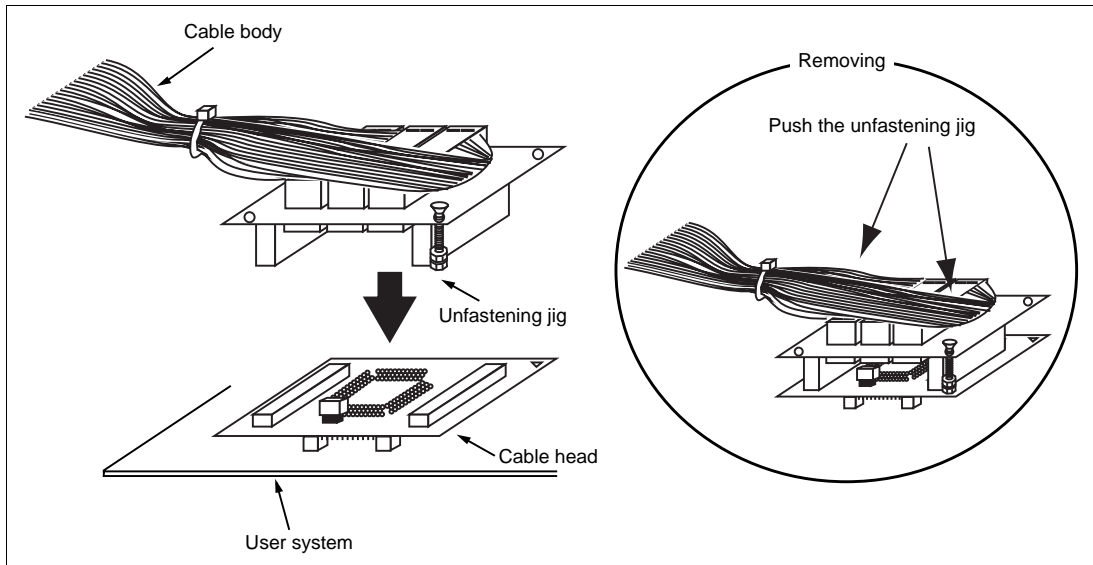

Figure 5 Fastening Cable Body

2.5 Resulting Dimensions after Connecting User System Interface Cable

The resulting dimensions, after connecting the user system interface cable head to the user system, are shown in figure 8.

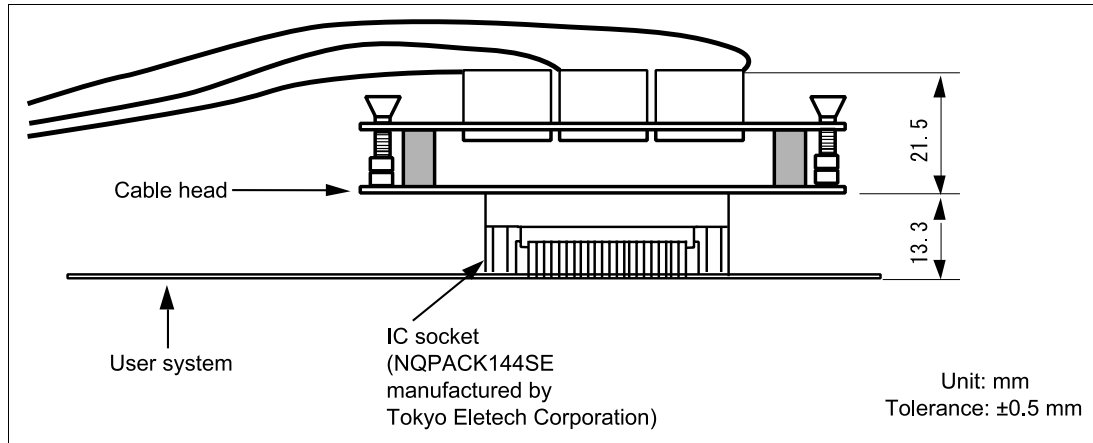

Figure 8 Resulting Dimensions after Connecting User System Interface Cable

Section 3 Installing the MCU to the User System

CAUTION

- 1. Check the location of pin 1 before inserting.**
- 2. Use a screwdriver whose head matches the screw head.**
- 3. The tightening torque must be 0.054 N•m or less.
If the applied torque cannot be accurately measured, stop tightening when the force required to turn the screw becomes significantly greater than that needed when first tightening. If a screw is tightened too much, the screw head may break or an IC socket contact error may be caused by a crack in the IC socket solder.**
- 4. If the MCU does not operate correctly, cracks might have occurred in the solder. Check conduction with a tester and re-solder the IC socket if necessary.**

Check the location of pin 1 before inserting the MCU into the IC socket on the user system, as shown in figure 9. After inserting the MCU, fasten the socket cover with the provided four screws (M2.0 x 6 mm). Take special care, such as manually securing the IC socket soldered area, to prevent the IC socket from being damaged by overtightening the screws or twisting the components.

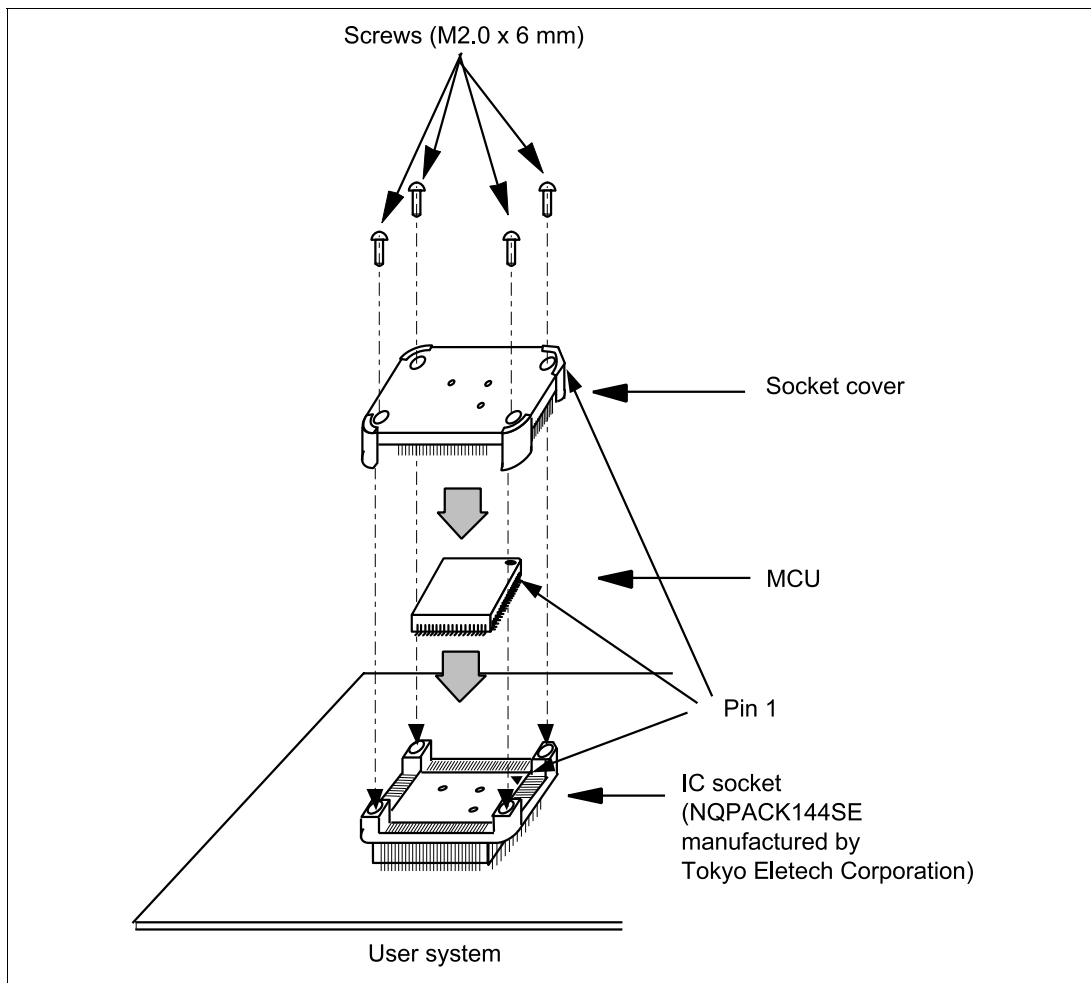

Figure 9 Installing MCU to User System

Section 4 Verifying Operation

1. When using the E6000 emulator for the H8S/2148 series, turn on the emulator according to the procedures described in the H8S Series E6000 Emulator User's Manual (HS2000EPI61HE).
2. Verify the user system interface cable connections by accessing the external memory and ports to check the bus states of the pins with the MEMORY_FILL command (emulator command). If an error is detected, recheck the soldered IC socket and the location of pin 1.
3. The emulator connected to this user system interface cable supports two kinds of clock sources as the MCU clock: an emulator internal clock and an external clock on the user system. For details, refer to the Emulator Supplementary Information (HS2148EPI61HE).
 - To use the emulator internal clock
Select the clock in the emulator station as the system clock (ϕ), by using the CLOCK command (emulator command).
 - To use the external clock on the user system
Select the target clock Target or Target/2 with the CLOCK command (emulator command).
Supply the external clock from the user system to the emulator by inputting the external clock from the EXTAL terminal on the cable head or connecting a crystal oscillator to the EXTAL and XTAL terminals. For details, refer to the Clock Pulse Generator section, in the H8S/2169 Series Hardware Manual.

Figure 10 shows the oscillator circuit on the user system interface cable.

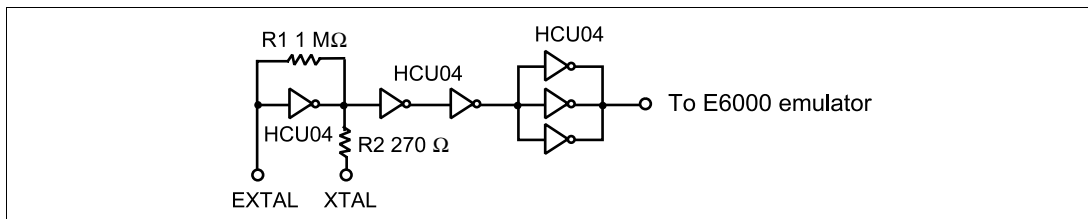

Figure 10 Oscillator Circuit

Section 5 Notice

1. Make sure that pin 1 on the user system IC socket is correctly aligned with pin 1 on the cable head before inserting the cable head into the user system IC socket.
2. The dimensions of the recommended mount pad for the user system IC socket are different from those of the MCU.
3. To avoid breaking wires in the cable body, do not place heavy or sharp metal objects on the user system interface cable.
4. While the emulator station is connected to the user system with the user system interface cable, force must not be applied to the cable head. Position the emulator station, user system interface cable, and user system as shown in figure 11.

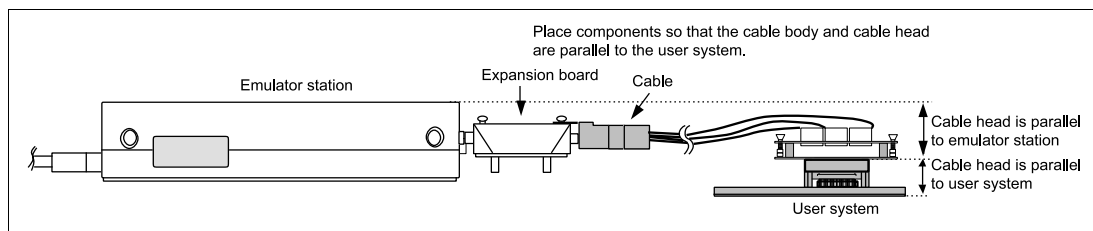

Figure 11 User System Interface Cable Location Example

5. The P1 short connector is for testing. Do not remove the jumper pin inserted in the side of pin 1 and pin 2.

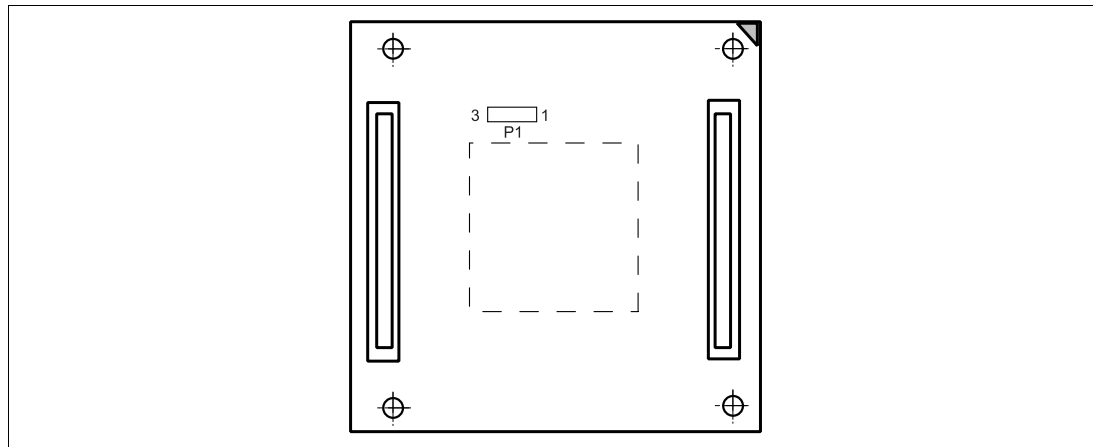

Figure 12 P1 Short Connector